

Specification Sheet For TKH15 Safety Glasses

Item Number:	TKH15	Series:	Tomahawk
Description:	Tomahawk bifocal magnifier 1.5, clear lens	Features:	5-position ratchet temples Extension adjustment temples 4 diopter strengths available-1.0, 1.5, 2.0, & 2.5 Nylon frame
Benefits:	Total eye protection for people needing magnifying lens Lightweight nylon frame	Case Pack:	72 pr.
		Weight:	1.89 oz.
		Case Weight:	136.08 oz.

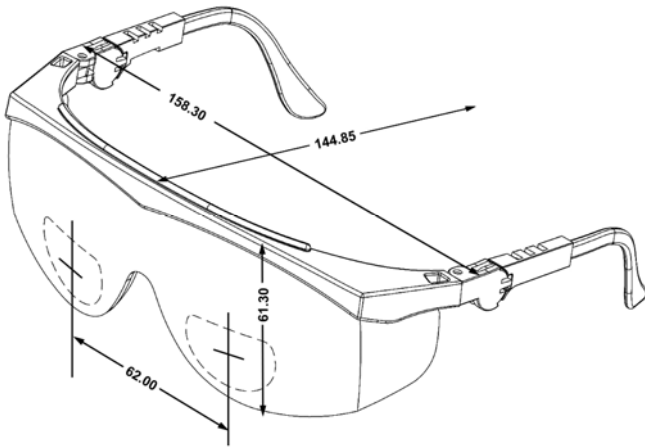

Materials

Frames		Lens	
Material:	Nylon	Material:	Polycarbonate
Temples:	Ratchet Spatula	Coatings:	Duramass (scratch-resistant)
Color:	Black	Colors:	See Below
Options:		Options:	

More Information

Available Lens:	Clear:	X	Clear Anti-Fog:	
	Grey:	X	Grey Anti-Fog:	
	Brown:		Brown Anti-Fog:	
	Amber:		Silver Mirror:	
	Indoor/Outdoor Clear Mirror:		Rainbow Mirror:	
	Light Blue:		Red Mirror:	
	Banana Mirror:		Copper:	
	Blue Mirror:			
Country of Origin:	Taiwan			
Ratings:	Meets or Exceeds ANSI Z87.1 2003 Safety Standards.			