

Specification Sheet For LW312AF Safety Glasses

Item Number:	LW312AF	Series:	Law 3
Description:	Law 3 smoke temples, anti fog gray lens with open cell foam seal	Features:	Soft temple inserts Soft secure gel nose pads Open cell foam seal Duramass® scratch-resistant coating Dielectric Meets or Exceeds ANSI Z87.1 Standard Meets CAN/CSA Z94.3-02 Standard
Benefits:	Offer additional comfort with grip For superior resistance to scratches Safe for Utility / Electrical work Protection from dust, wind, and small particles Meets the ANSI standards for high impact	Case Pack:	144 pr.
		Weight:	1.395 oz.
		Case Weight:	200.880 oz.

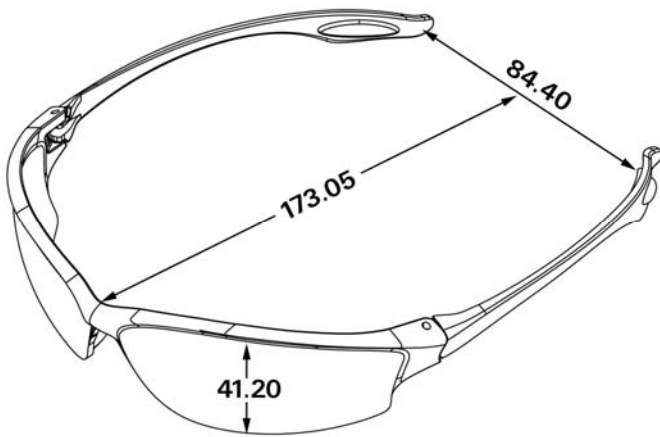

Materials

Temples		Lens	
Material:	Nylon – Integrated Frame	Material:	Polycarbonate
Temples:	Bayonet	Coatings:	Duramass® scratch-resistant
Color:	Smoke	Colors:	See Below
Options:		Options:	

More Information

Available Lens:	Clear:		Clear Anti-Fog:	X
	Gray:		Gray Anti-Fog:	X
	Light Blue:		Brown Anti-Fog:	
	Amber:		Silver Mirror:	
	Indoor/Outdoor Clear Mirror:		Rainbow Mirror:	
	Filter 3.0		Filter 5.0	

Country of Origin:	Taiwan
Ratings:	Meets or Exceeds ANSI Z87.1 Safety Standards. Meets CAN/CSA Z94.3-02 Safety Standards.